

PCT/IE 01/00118

REC'D 04 OCT 2001	
WIPO	PCT



Patents Office  
Government Buildings  
Hebron Road  
Kilkenny

I HEREBY CERTIFY that annexed hereto is a true copy of documents filed in connection with the following patent application:

Application No. S2000/0724  
Date of Filing 8 September 2000

**PRIORITY DOCUMENT**  
SUBMITTED OR TRANSMITTED IN COMPLIANCE WITH RULE 17.1(a) OR (b)

Applicant JAMES COLEMAN, an Irish citizen of 20 Greenmount Road, Terenure, Dublin 6, Ireland; CHRISTY CUMMINS, an Irish citizen of 54 Knockowen, Tullamore, County Offaly, Ireland; CHRIS MARTIN, an Australian citizen of 2 Blackburn Square, Rathfarnham, Dublin 14, Ireland; THOMAS ANTHONY, an Irish citizen of 49 Grange Downs, Rathfarnham, Dublin 14, Ireland; SEAN MORRIS, an Irish citizen of Newpark, Kiltoom, Athlone, County Roscommon, Ireland.

Dated this 24<sup>th</sup> day of September 2001.

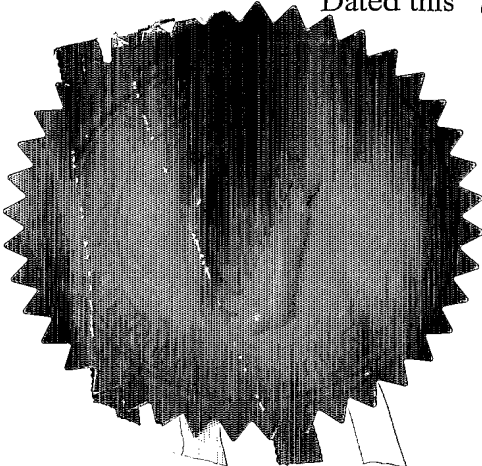

An officer authorised by the  
Controller of Patents, Designs and Trademarks.

S 000724

FORM NO. 1

REQUEST FOR THE GRANT OF A PATENT  
PATENTS ACT, 1992

The Applicant named herein hereby request

the grant of a patent under Part II of the Act

the grant of a short-term patent under Part III of the Act

on the basis of the information furnished hereunder.

1. APPLICANT

Name

1. James Coleman,
2. Christy Cummins,
3. Chris Martin,
4. Thomas Anthony,
5. Sean Morris.

Address

1. 20 Greenmount Road, Terenure, Dublin 6;
2. 54 Knockowen, Tullamore, County Offaly;
3. 2 Blackburn Square, Rathfarnham, Dublin 14;
4. 49 Grange Downs, Rathfarnham, Dublin 14;
5. Newpark, Kiltoom, Athlone, County Roscommon.

Description/Nationality

- 1, 2, 4, 5: Irish  
3: Australian.

2. TITLE OF INVENTION

"Surgical Staple"

3. DECLARATION OF PRIORITY ON BASIS OF PREVIOUSLY FILED  
APPLICATION FOR SAME INVENTION (SECTIONS 25 & 26)

Previous filing date

Country in or for which filed

Filing No.

4. IDENTIFICATION OF INVENTOR(S)

Name(s) of person(s) believed by Applicant(s) to be the inventor(s)

1. Thomas Anthony
2. Chris Martin
3. Sean Morris
4. Christy Cummins
5. James Coleman.

Address

1. 49 Grange Downs, Rathfarnham, Dublin 14;
2. 2 Blackburn Square, Rathfarnham, Dublin 14;
3. Newpark, Kiltoom, Athlone, County Roscommon;

- 4. 54 Knockowen, Tullamore County Offaly;
- 5. 20 Greenfield Road, Terenure, Dublin 6.

5. **STATEMENT OF RIGHT TO BE GRANTED A PATENT (SECTION 17(2)(B))**

The Applicants are the Inventors

6. **ITEMS ACCOMPANYING THIS REQUEST - TICK AS APPROPRIATE**

- (i)  prescribed filing fee (£50.00)
- (ii)  specification containing a description and claims  
 specification containing a description only  
 Drawings referred to in description or claims
- (iii)  An abstract
- (iv)  Copy of previous application(s) whose priority is claimed
- (v)  Translation of previous application whose priority is claimed
- (vi)  Authorisation of Agent (this may be given at 8 below if this Request is signed by the Applicant(s))

7. **DIVISIONAL APPLICATION**

The following information is applicable to the present application which is made under Section 24

Earlier Application No:

Filing Date:

8. **AGENT**

The following is authorised to act as agent in all proceedings connected with the obtaining of a Patent to which this request relates and in relation to any patent granted -

**Name**

F. R. KELLY & CO.

**Address**

at their address as recorded for the time being in the Register of Patent Agents

9. **ADDRESS FOR SERVICE (IF DIFFERENT FROM THAT AT 8)**

JAMES COLEMAN, CHRISTY CUMMINS, CHRIS MARTIN,  
THOMAS ANTHONY and SEAN MORRIS

F. R. KELLY & CO.

By:

  
 EXECUTIVE

Date: September 8, 2000

08 SEP 2000

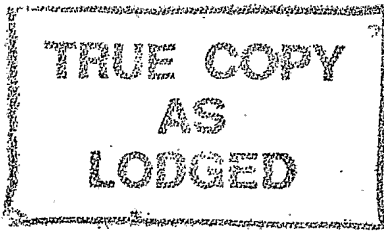

S 000724

~~APPLICATION~~

SURGICAL STAPLE

The present invention relates a surgical staple, for closing a puncture in a blood vessel by applying a staple across the puncture so as to affect a closure and prevent bleeding. The invention relates particularly to surgical staplers for closing punctures in blood vessels.

10 When performing catheterisation procedures, such as angiography or angioplasty, a catheter is generally introduced into the vascular system by first penetrating the skin, underlying tissues and blood vessel with a sharpened hollow needle. Next, a  
15 guidewire is commonly inserted through the lumen of the hollow needle and is caused to enter the selected blood vessel. Subsequently the needle is typically stripped off the guidewire and a combination of a dilator and/or introducer (or an introducer alone) are fed over the  
20 guidewire and pushed through the skin to enter the blood vessel. The guidewire can then be removed and a desired catheter to carry out the procedure is fed through the lumen of the introducer and advanced through the vascular system until the working end of  
25 the catheter is appropriately positioned. Following the conclusion of the catheterisation procedure the working catheter will be withdrawn and subsequently the dilator and/or introducer will also be removed from the wound. Following this procedure the vessel puncture

must be closed in order to prevent loss of blood through the puncture hole.

Typically the wound is closed by maintaining external  
5 pressure over the vessel until the puncture naturally seals. This procedure can take approximately 30 minutes with the length of time usually being greater if the patient is hypertensive or anticoagulated. The procedure can also be uncomfortable for the patient and  
10 involves costly professional time on the part of the hospital staff. Other pressure techniques such as pressure bandages, sandbags or clamps have been employed but these also involve ensuring the patient remains motionless for an extended period of time and  
15 is monitored to ensure the effectiveness of the procedure.

A number of devices have been developed in recent times which provide an obstruction in the area of the  
20 puncture in order to prevent bleeding. For example, US Patents 4,852,568 and 4,890,612 disclose a device which utilises a collagen plug which when placed at the blood vessel opening absorbs body fluids, swells and affects a seal. Other plug like devices, for example  
25 US 5,222,974 and US 5,282,827, describe a plug and anchor device, the anchor being positioned inside the vessel and the collagen plug outside the vessel thereby sandwiching the puncture between both and effecting a closure..

WO 98/17179 discloses a surgical stapler having a blood locator tube adjacent the stapling head. A guidewire passes through an opening at the end of the tube and up  
5 through a hollow bore in the tube, so that the stapler can be fed onto the guidewire and down onto the puncture site. When the device reaches the puncture site, the tip of the tube enters the blood flow within the artery and blood passes through the tube and out of  
10 the distal end at a point visible to the clinician. The clinician can then actuate the stapling mechanism in the knowledge that the stapling head is at the puncture site in the arterial wall.

15 It is an object of the present invention to provide an improved surgical staple for closing a puncture in a liquid-carrying vessel. It is a further object of the invention to provide an improved stapler for use with such a staple.

20 According to the present invention there is provided a surgical staple comprising a base and a respective leg extending at an angle from each end of the base and terminating at a free end, the base and legs lying in  
25 substantially a common plane except for a centre portion of the base which is deformed generally in a U-shape in a direction perpendicular to the common plane of the legs.

In another aspect the invention provides a surgical stapler in combination with a surgical staple, wherein:

the staple comprises a base and a respective leg extending at an angle from each end of the base and terminating at a free end, the base and legs lying in substantially a common plane except for a centre portion of the base which is deformed generally in a U-shape in a direction perpendicular to the common plane of the legs; and

the stapler comprises a shaft, an elongated locator means slidable axially within the shaft between a forward position wherein the locator means projects beyond a free end of the shaft to enter a puncture site in a blood vessel, thereby to locate the free end of the shaft at the puncture site, and a rearward position wherein the locator means is retracted relative to the shaft, said staple straddling the locator means and slidable forwardly thereon, with the locator shaft disposed within said U-shaped centre portion, anvil means against which the staple may be deformed to staple together the opposite edges of the puncture site, and actuator means for driving the staple forwardly along the locator means into deforming engagement with the anvil means and for retracting the locator means in co-ordination with the movement of the staple such that the locator means is withdrawn from between the legs of the staple in time to allow the legs of the staple to close onto the puncture site.

Preferably, the angle at which the legs extend from the base is close to perpendicular. In a particularly preferred embodiment, the leg makes an internal angle with respect to the base of from about 70° to about 85°, more preferably from about 75° to about 80°.

An embodiment of the invention will now be described, by way of example, with reference to the accompanying drawings, in which:

10

Fig. 1 is a perspective view of the surgical staple in the pre-fired (pre-deformed) state according to the invention;

15

Fig. 2 is a perspective view of the surgical staple in the post-fired (deformed) state according to the invention;

20

Fig. 3 is a perspective view of an embodiment of a surgical stapler according to the invention;

Fig. 3(A) is an enlarged perspective view of the free end of the shaft of the stapler of Fig. 3;

25

Fig. 4 is a perspective view of the internal components at the free end of the shaft and omitting the left hand side of the shaft, showing the staple and firing components in their pre-fired position;



Fig. 5 is a perspective view of the components seen in Fig. 4, showing the position of the components in mid-cycle with the staple in the fully formed state;

5 Fig. 6 is an exploded view of the internal components of the free end of the shaft, omitting the left hand side of the shaft; and

10 Fig. 7 is a perspective view of the blood locator tube with exploded views of the front and rear portions shown in Figs. 7A and 7B, respectively.

Referring to the drawings, the stapler comprises a rigid shaft 10 extending from a moulded plastics housing 12 shaped in the form of a pistol-like handle. 15 The shaft 10, which is hollow to accommodate various moving components to be described, comprises right and left hand sides 10A, 10B respectively, which are secured together along their length. Likewise, the 20 housing 12 comprises left and right hand sides 12A, 12B respectively.

The major part of the exposed length of the shaft 10 has a constant circular cross-section, but at its free 25 end the shaft 10 has a portion 14 of increased diameter having a "bullet" profile. One end of this bullet portion 14 is tapered down toward a staple exit slot 16 while the other end is tapered down to the remaining

section of the shaft which extends back into the housing 12.

The reason for the bullet profile is so that there is  
5 sufficient diameter of the shaft's free end to house  
the staple and forming components, whilst keeping the  
shaft 10 as atraumatic as possible during introduction  
to the body to minimise the amount of force and tissue  
dilation required when tracking the device over a  
10 guidewire 18 and onto the surface of a blood vessel  
adjacent a puncture hole, as will be described. In  
alternative embodiments (not shown), the bullet portion  
14 may be elliptical in cross-section with the major  
axis of the ellipse being coincident with the staple  
15 exit slot 16, so as to minimise the circumferential  
length for a given staple width.

The bullet portion 14 of the shaft 10 houses the staple  
delivery components shown in Fig. 4, which is operated,  
20 via rod-like actuating members slidable in the shaft  
10, by a trigger-operated cam mechanism in the housing  
12.

The staple delivery mechanism comprises an anvil 24  
25 (see especially Fig. 6) having a pair of upstanding  
fingers 24A at the front and a pair of downwardly  
inclined tilt arms 24B at the rear. The anvil 24 is  
tiltably mounted in the bullet portion 14 by a pair of  
wings 26 which are pivotable in recesses 28 (Fig.6) in

the right hand side 10A of the shaft 10 (the wings are retained in the recesses by the under surface of the former projections 54 shown in Fig. 4).

5 Tilting of the anvil 24 is effected by an elongated anvil support 30 which is slidable axially within the shaft 10. The anvil support 30 is caused to move by a cam mechanism which is actuated by depressing the trigger (Fig. 3). The front end of the anvil support  
10 30 is bifurcated to form two arms 34 having lateral projections 36. These projections slide in rebates 38 (Fig. 6) in the right hand side 10A of the shaft. The anvil support 30 is movable, by the cam mechanism, from a forward position, Fig. 4, wherein the arms 34 extend  
15 under the fingers 24A and support them directly in front of a surgical staple 40 to be delivered, and a rearward position, Fig. 5, wherein the arms 34 are withdrawn under the downwardly inclined tilt arms 24B at the rear of the anvil 24 so as to tilt the anvil  
20 anti-clockwise and displace the fingers 24A out of the path of the staple 40.

A hollow blood locator tube 42 is slidable axially within the shaft 10 in a channel 44 in the anvil  
25 support 30. The tube 42 extends the full length of the shaft 10 and has a constant, generally oval cross-section except at its tip 42A where it tapers to a narrow opening 46A whose diameter is less than the maximum diameter of the tube, Fig. 7. Under the action

of the cam mechanism the tube 42 is slidable axially of the shaft 10 between a forward position, Figs. 4, wherein its front end projects beyond the bullet portion 14 of the shaft 10, and a rearward position, 5 Figs. 5, wherein the front end of the tube 42 is retracted within the bullet portion 14 behind the fingers 24A of the anvil 24.

The purpose of the blood locator tube 42 is to follow a 10 previously placed guidewire 18 to a puncture site in a blood vessel, thereby to locate the bullet portion 14 of the shaft 10 against the exterior wall of the blood vessel at the puncture site. To properly locate the bullet portion 14 the front end of the tube 42 must 15 actually penetrate the blood vessel through the puncture site and this is indicated by blood flowing back through the tube 42 and out through a blood outlet port 48 (Fig. 6) in the tube. A channel (not shown) in the part of the left hand side 10B of the shaft 10 20 within the housing 12 communicates the port 48 with a blood exit port 50 (Fig. 3) on the side of the housing 12, so that the blood pumped back through the tube 42 is visible at the exterior of the housing.

25 It has been found that the naturally formed shape of puncture wounds in arterial walls is elongated rather than round. Whereas the hole is formed by introducing instruments generally of round cross section, the wall tends to open generally along a transverse line which

lies in the direction of the circumference of the artery (rather than along the axis of the artery). By having a generally oval blood locator tube, the locator tube (when introduced by the clinician with the major axis of the oval perpendicular to the axis of the artery), will fit more naturally within the arterial opening. The consequence of this is that the wound edges which are to be stapled together, lie closer together than if a tube of circular cross section were to be used.

This in turn has the consequence that the staple used need not be so large, and in turn, the dimensions of the shaft, which must accommodate the staple when in its unformed state, can be reduced, leading to less trauma for the tissue into and from which the shaft is introduced.

A further consequence of having a generally oval or elongated cross section for the locator tube is that the tube will be more disposed to the centre of the puncture than with a rounded tube. The invention has a staple which straddles the locator tube, thereby increasing the likelihood of the staple closing the elongated wound at its centre rather than towards one or other of the extremities of the wound.

The staple straddles the blood locator tube within the bullet portion of the shaft, see Figs.

4 and 5, and is slidable thereon forwardly towards the free end of the bullet portion 14. In particular, the staple 40 comprises a back or base portion 40A from which extend at an angle at each end respective legs 5 40B which terminate in sharpened points 40D. The internal angle between the legs 40B and base 40A is chosen to be close to perpendicular, but is in fact about  $75^{\circ}$ - $80^{\circ}$ . The tips of the points 40D are directed inwardly, i.e. in the direction in which the legs 40B 10 are closed in use, as shown in Fig. 2. The point geometry, angles of projecting legs 40B to base 40A and the length of legs 40B are configured to aid in keeping the closing staple within the thickness of the arterial wall and prevent the staple-points 40D penetrating into 15 the arterial lumen, and additionally to avoid snagging on or dislodging any atheromatous or calcified plaque within the intimal layer of the arterial wall. The base portion 40A and legs 40B lie in substantially a common plane except for a centre portion 40C of the 20 base portion 40A which is deformed in a direction perpendicular to the legs 40B so as to have a U-shape complementary to the external cross-sectional profile of the blood locator tube 42. The staple 40 is mounted on the blood locator tube 42 such that the centre 25 portion 40C of the staple sits on the upper half of the tube 42, as seen in Fig. 4, with the legs 40B pointing forwardly on opposite sides of the tube 42. The depth of the centre portion 40C of the staple 40 is such that the legs 40B of the staple lie substantially directly

on opposite sides of the central axis of the tube 42. This will ensure that the staple 40 is positioned centrally across the puncture hole in the blood vessel. In order to avoid the guidewire 18 fouling the staple  
5 40 when the latter is closed on the puncture site, the hole 46 (Fig. 7) is offset below the plane containing the legs 40B of the staple.

The staple delivery mechanism further includes an  
10 elongated former 52 having a cross-section conforming to that of the blood locator tube 42 and slidable on the blood locator tube 42 axially within the shaft 10. The former 52 is located behind the staple 40 on the tube 42 and is operated by the cam mechanism (not  
15 shown). At its front end the former 52 has a pair of forming arms 54 which are so shaped that, when the former 52 is driven forward by the cam mechanism, the staple 40 is driven against and deformed around the anvil fingers 24A so that the legs 40B of the staple  
20 close together (Fig. 5) onto the puncture site. During such movement the staple legs slide toward the anvil 24 in moulded tracks 16 within the bullet portion 14. These tracks provide a slight interference fit on the staple legs 40B to prevent the staple 40 moving forward  
25 prior to firing and during storage of the device.

In use, the stapler is initially in the "pre-fire" configuration shown in Figs. 1 and 4. The front end of the blood locator tube 42 is in a fully forward

position projecting beyond the free end of the bullet portion 14 of the shaft 10, the anvil support 30 is in a fully forward position with its arms 34 extending under the anvil fingers 24A and supporting them directly in front of the staple 40, the former 52 is in a fully retracted position away from the anvil fingers 24A, and the staple 40 is in its full back position up against the forming arms 54.

10 In this configuration the external end of a previously positioned guidewire 18 is inserted into the hole 46 in the front end of the blood locator tube 42 and fed through the tube 42 until it exits a guidewire exit port at the rear of the housing 12. The stapler is now  
15 fed along the guidewire 18 until the distal tip 42A of the tube 42 enters the blood vessel lumen through the puncture hole. This is indicated by blood pulsing out of the blood exit port 50. At this point the front end of the bullet portion 14 of the shaft 10 will be  
20 resting against the exterior wall of the blood vessel.

Now the trigger 56 is squeezed, causing the cams to rotate through 90 degrees. The rear end of each of the blood locator tube 42, anvil support 30 and former 52  
25 are coupled to the cam mechanism via cam followers and the following co-ordinated movement of these components takes place as the cams rotate through 90 degrees.



- 0 degrees: Stapler in pre-fire configuration as described above (Fig. 4).
- 5 30 degrees: Former 52 moved forward pushing staple 40 ahead of it; blood locator tube 42 retracting.
- 10 40 degrees: Former 52 and staple 40 further forward; blood locator tube 42 further retracted.
- 15 50 degrees: Former 52 forward sufficiently to clamp staple 40 against anvil fingers 24A; blood locator tube 42 further retracted. At this point the staple legs 40B will have punctured wall of blood vessel but staple not yet deformed.
- 20 58 degrees: Former 52 forward sufficiently to deform the staple legs 40B around the anvil fingers 24A and close the staple on puncture site (Fig. 5); blood locator tube 42 fully retracted. At some point between 50 and 58 degrees the blood locator tube 42 will have withdrawn from
- 25 between the staple legs 40B in time to allow them to close. This should be left as late as possible to provide support for the walls of the blood vessel for as long as possible.

65 degrees: Former 52 retracted slightly to release clamp force on staple 40. Anvil support 30 starting to retract.

5

77 degrees: Anvil support 30 retracted to clear anvil fingers 24A.

10

90 degrees: Anvil support 30 fully retracted under tilt arms 24B; anvil fingers 24A dropped down to release staple.

The invention is not limited to the embodiments described herein and may be modified or varied without departing from the scope of the invention.

15

## CLAIMS

1. A surgical staple comprising a base and a  
respective leg extending at an angle from each end of  
5 the base and terminating at a free end, the base and  
legs lying in substantially a common plane except for a  
centre portion of the base which is deformed generally  
in a U-shape in a direction perpendicular to the common  
plane of the legs.
- 10 2. A surgical staple according to claim 1, wherein  
said angle is an internal angle between the leg and the  
base of from about  $70^\circ$  to about  $85^\circ$
- 15 3. A surgical staple according to claim 2, wherein  
said internal angle is from about  $75^\circ$  to about  $80^\circ$ .
4. A surgical stapler in combination with a surgical  
staple, wherein:
- 20 the staple comprises a base and a respective leg  
extending at an angle from each end of the base and  
terminating at a free end, the base and legs lying in  
substantially a common plane except for a centre  
portion of the base which is deformed generally in a U-  
25 shape in a direction perpendicular to the common plane  
of the legs; and
- the stapler comprises a shaft, an elongated  
locator means slidable axially within the shaft between  
a forward position wherein the locator means projects

beyond a free end of the shaft to enter a puncture site in a blood vessel, thereby to locate the free end of the shaft at the puncture site, and a rearward position wherein the locator means is retracted relative to the shaft, said staple straddling the locator means and 5 slidable forwardly thereon, with the locator shaft disposed within said U-shaped centre portion, anvil means against which the staple may be deformed to staple together the opposite edges of the puncture 10 site, and actuator means for driving the staple forwardly along the locator means into deforming engagement with the anvil means and for retracting the locator means in co-ordination with the movement of the staple such that the locator means is withdrawn from 15 between the legs of the staple in time to allow the legs of the staple to close onto the puncture site.

5. A surgical staple as claimed in claim 4, wherein said angle is an internal angle between the leg and the 20 base of from about  $70^{\circ}$  to about  $85^{\circ}$

6. A surgical staple as claimed in claim 5, wherein said internal angle is from about  $75^{\circ}$  to about  $80^{\circ}$ .

25

7. A surgical stapler as claimed in claim 4, wherein the locator means has a generally oval cross-section.

8. A surgical stapler as claimed in claim 4, wherein the legs of the staple lie substantially directly on opposite sides of a central axis of the locator.

5 9. A surgical stapler as claimed in claim 4, wherein the locator comprises a tube having an opening at the forward end to enable blood flow to be sensed within a blood vessel to thereby locate the puncture site in the vessel.

10

10. A surgical stapler as claimed in claim 9, wherein the opening at the forward end of the locator is offset from between the legs of the staple.

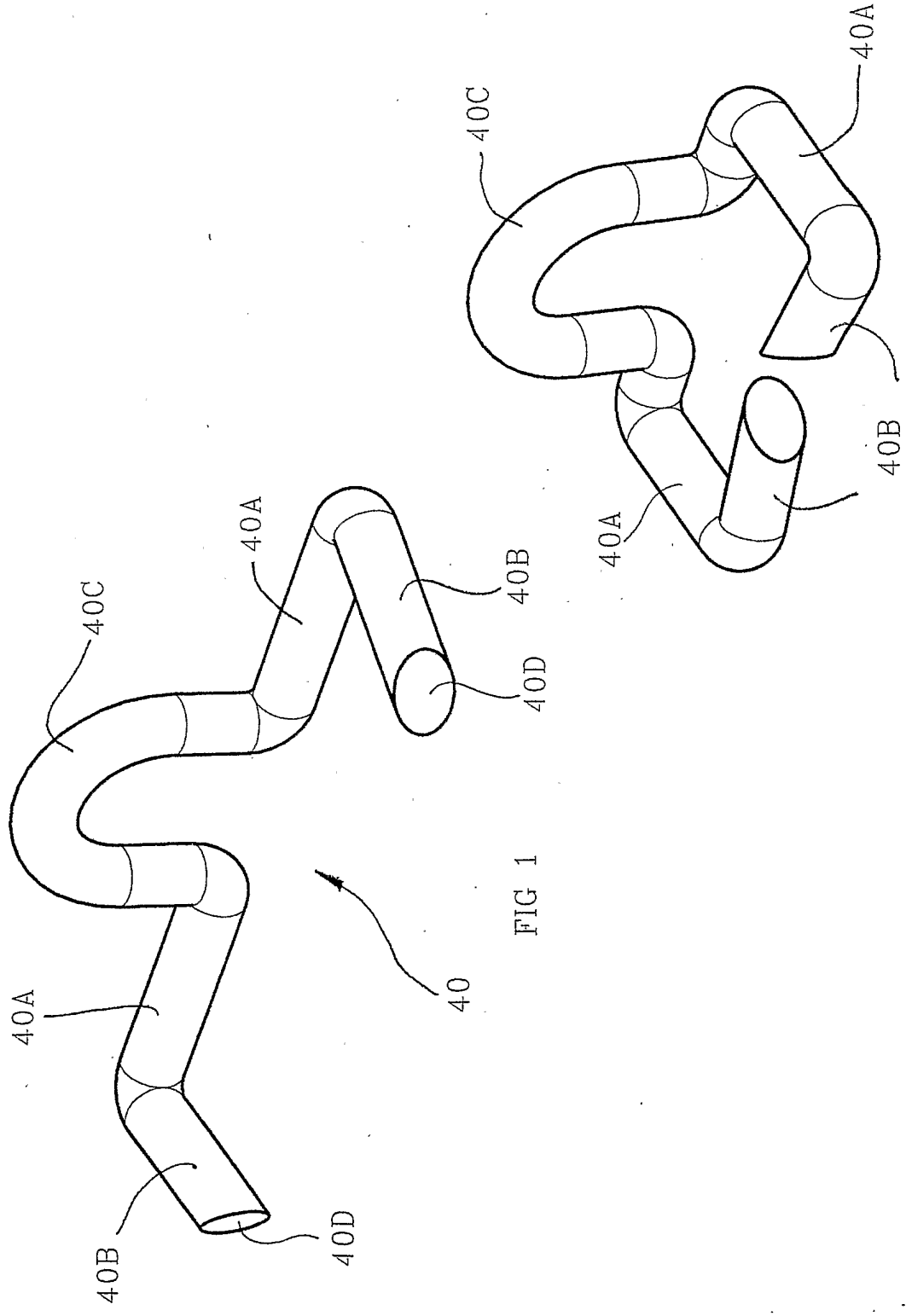

FIG 1

FIG 2

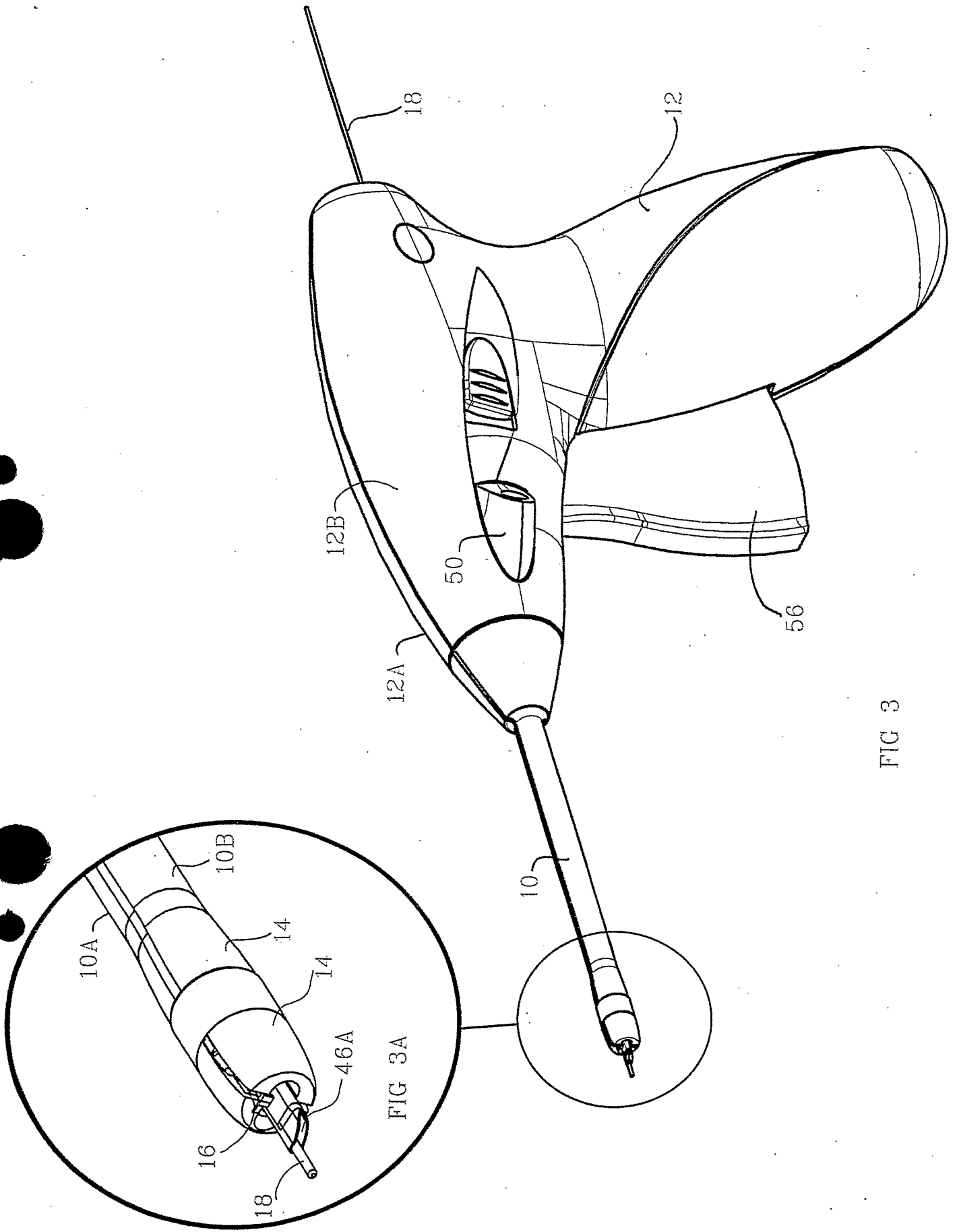

FIG 3

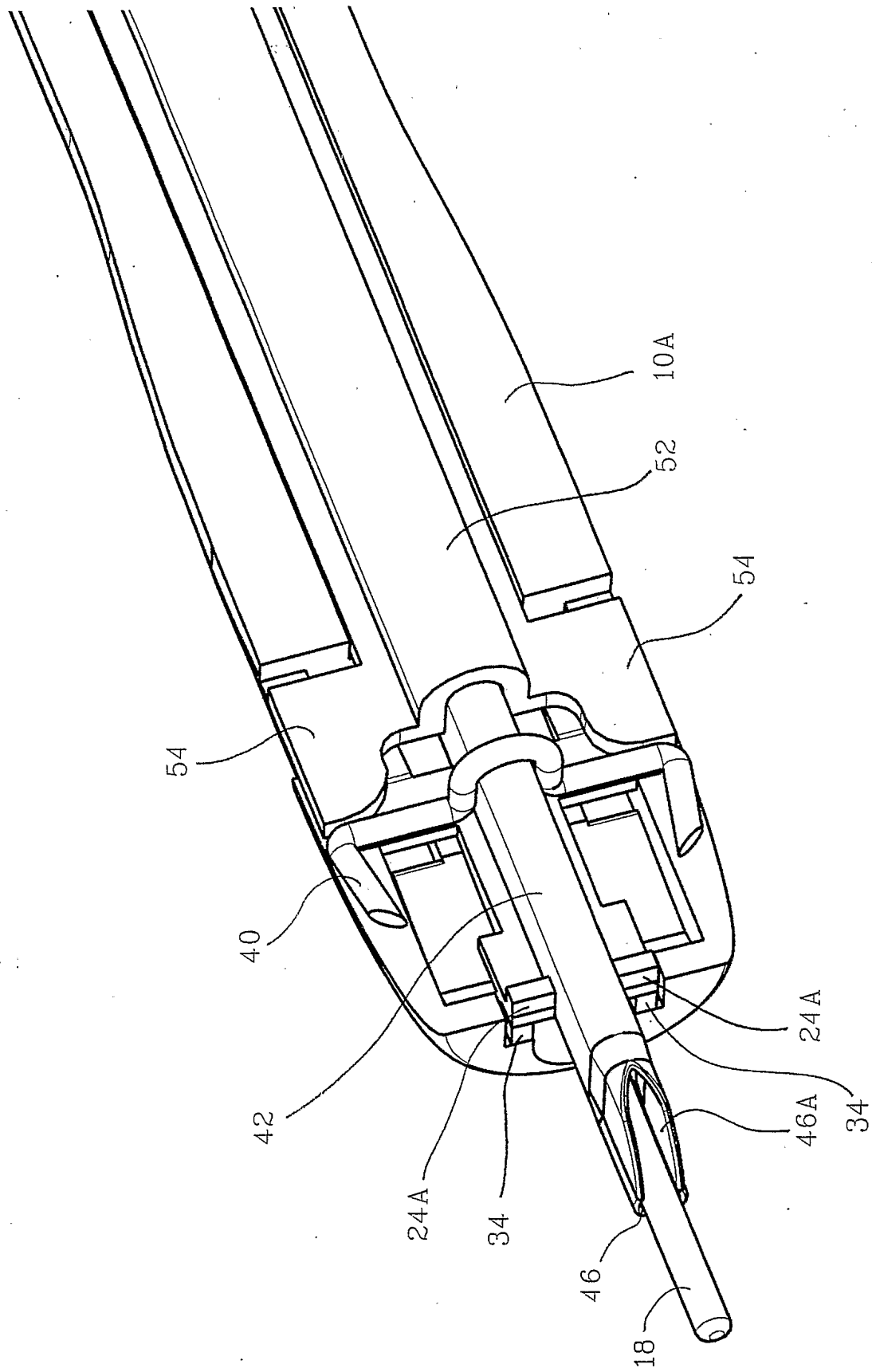

FIG 4



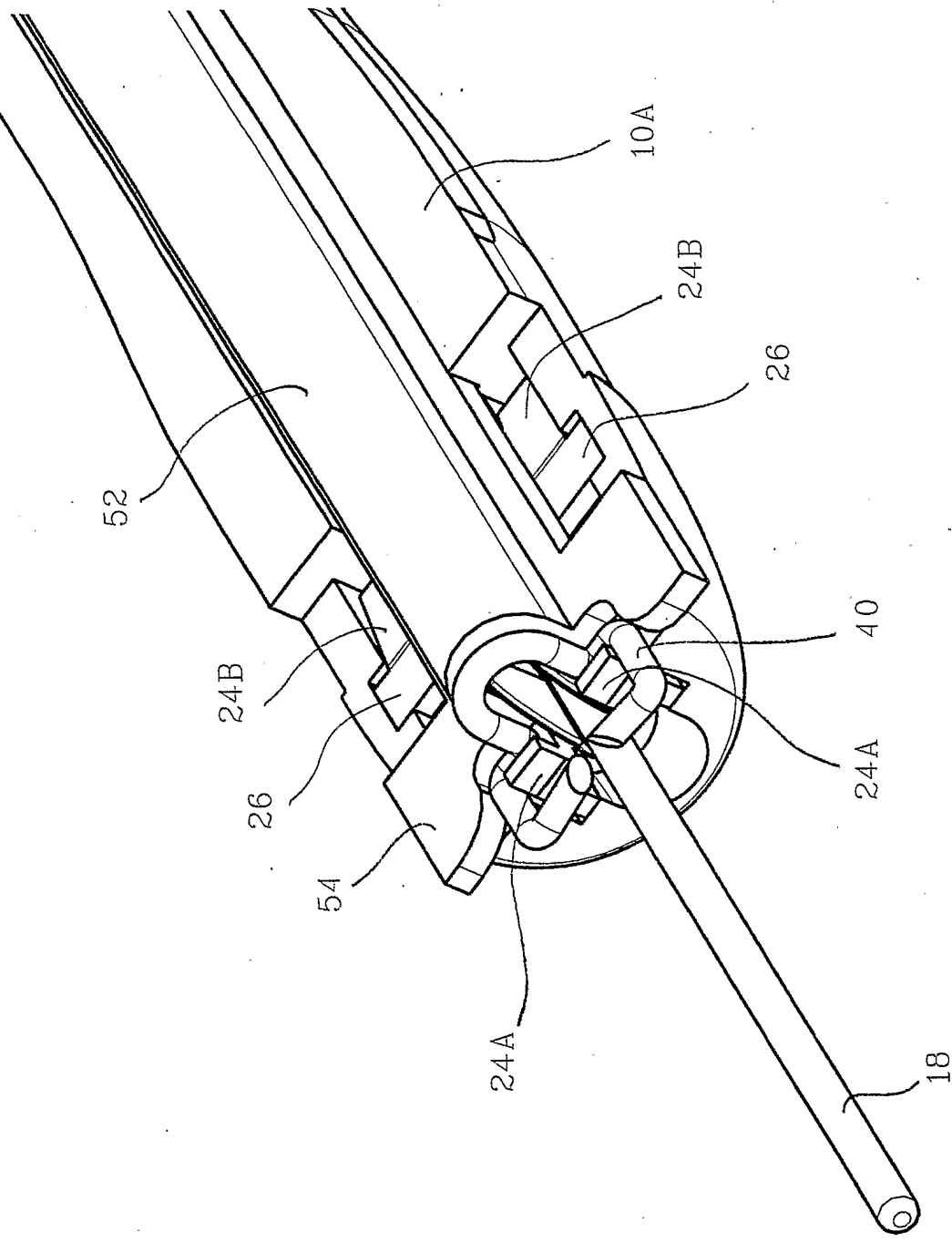

FIG 5

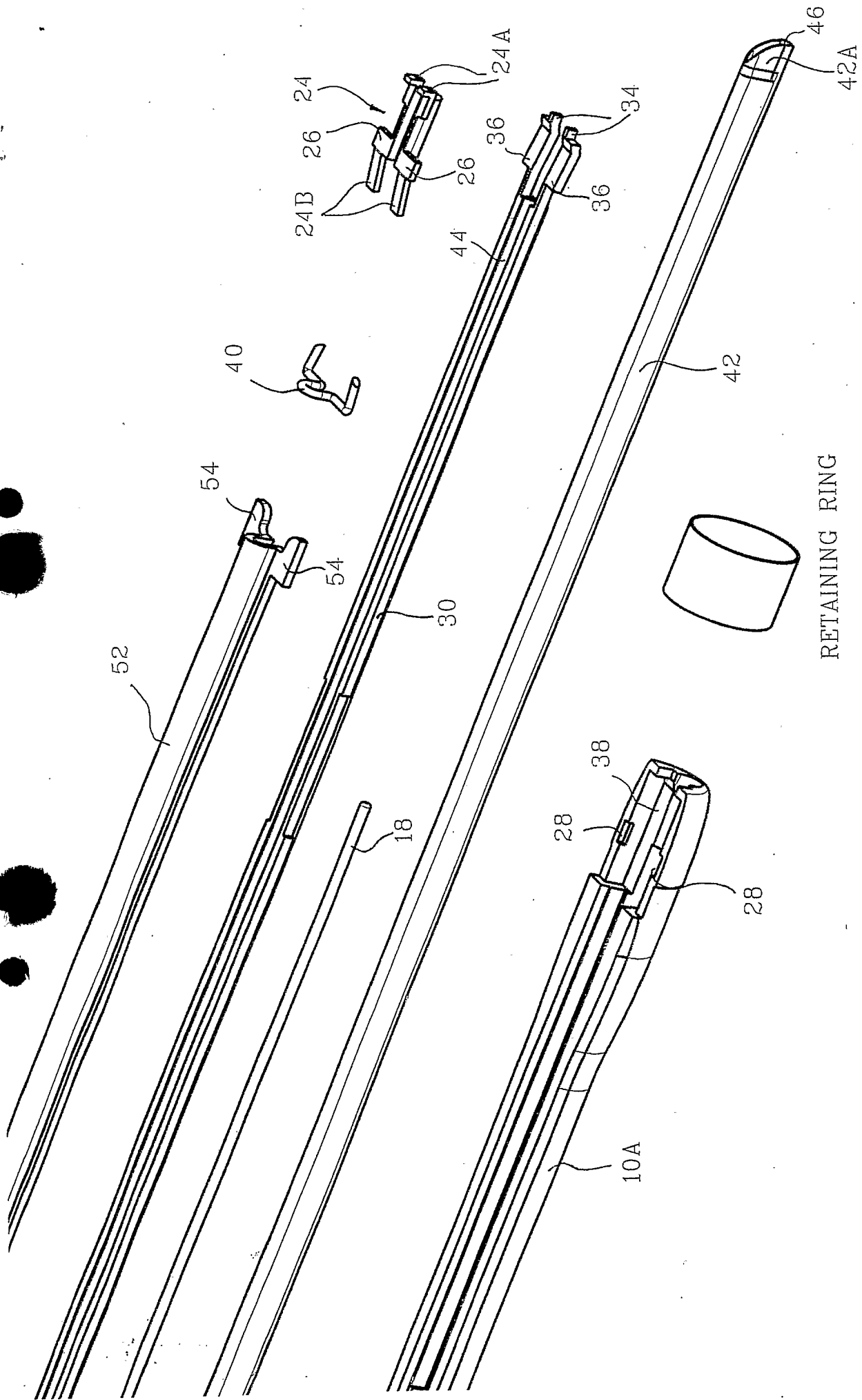

FIG 6

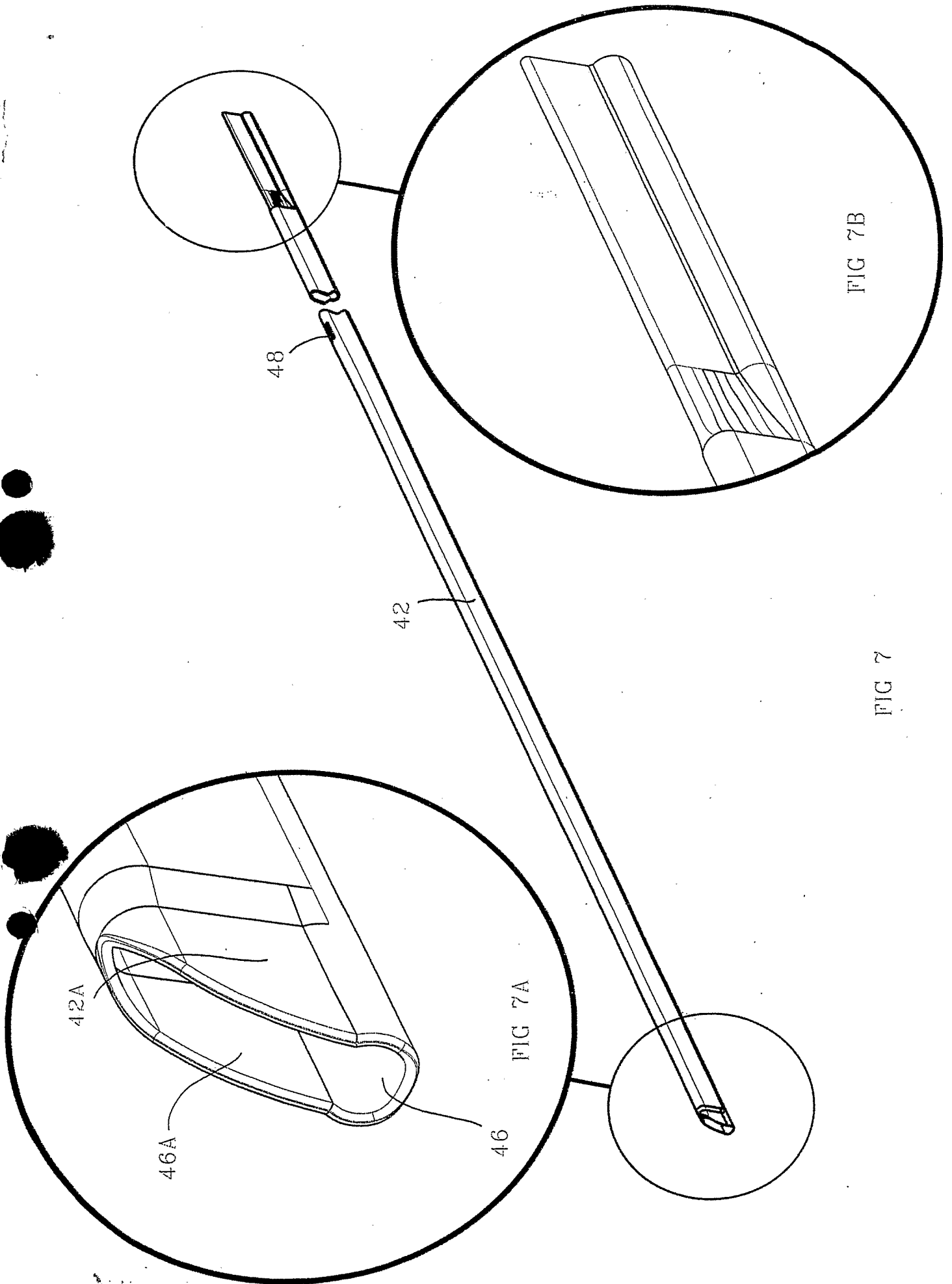

FIG 7

FIG 7B

FIG 7A